

**TECHNICAL MANUAL**

**OPERATOR'S, ORGANIZATIONAL, DIRECT SUPPORT  
AND GENERAL SUPPORT MAINTENANCE MANUAL  
INCLUDING REPAIR PART LISTS**

**FOR**

**AGITATOR, PAIN SHAKER  
MODEL 5033/DG  
(NSN 4940-00-251-6475)  
(RED DEVIL, INC.)**

---

**HEADQUARTERS, DEPARTMENT OF THE ARMY**

**JUNE 1981**

Technical Manual  
No. 9-4940-542-14&P



HEADQUARTERS  
DEPARTMENT OF THE ARMY  
Washington, DC, 1 June 1981

**Operator's, Organizational, Direct Support  
and General Support Maintenance Manual  
Including Repair Parts List  
For  
AGITATOR, PAINT SHAKER  
MODEL 5033/DG  
(NSN 4940-00-251-6475)**

**REPORTING ERRORS AND RECOMMENDING IMPROVEMENTS**

**You can help improve this manual. If you find any mistakes or if you know of a way to improve the procedures, please let us know. Mail your letter, DA Form 2028 (Recommended Changes to Publications and Blank Forms), or DA Form 2028-2, located in the back of this manual direct to: Commander, US Army Armament Materiel Readiness Command, ATTN: DRSAR-MAS, Rock Island, IL 61299. A reply will be furnished direct to you.**

**NOTE**

This manual is published for the purpose of identifying an authorized commercial manual for the use of the personnel to whom this equipment is issued.

Manufactured by: Red Devil, Inc.  
2400 Vauxhall Road  
Union, NJ 07083

Procured under Contract No. DAAA09-80-C-2061

**This technical manual is an authentication of the manufacturers' commercial literature and does not conform with the format and content specified in AR 310-3, Military Publications. This technical manual does, however, contain available information that is essential to the operation and maintenance of the equipment.**

**TABLE OF CONTENTS**

Operation, Service, Maintenance Manual  
For #5033/DG  
NSN-4940-00-251-6475

Mixer, Liquid, Agitator Type in Accordance with Military Specifications MIL-M'3070C, Type II, Size 1/2 H.P.

	<b><u>PAGE</u></b>
I Safety Precautions	1
II Operating Instructions	2
III Lubrication and Maintenance	2
IV Servicing	3, 4, 5, 6
V Parts List	7, 8, 9, 10
VI Instructions for using "odd size can and carton adapter"	11
VII Instructions for requisitioning parts not identified by Federal Stock number	11

**OPERATION, SERVICE & MAINTENANCE MANUAL**  
**for 5033/DG** **Paint Conditioner**

**I. SAFETY PRECAUTIONS**

1. Make certain machine is firmly secured to floor. This can be accomplished with two pieces of 6 x 6's or with #5054 optional base. #5054 Base - Invert the base and set it on two 4 x 4's. Place washers on the bolts supplied with the base. Insert these bolts into four bushings (pipes). Mix up cement and pour it into the base. Level of the cement should be approximately ¼ to ½" below the sides of the base. Allow it to stand for two days. After you have turned the base over, place a #39 rubber foot on each bolt and set the machine into place. Place a washer and nut on each bolt and tighten. Lag each corner of the base to the floor.

Base made up from 6 x 6's - Obtain two each 6 x 6's 24" in length. Since one is to be placed under the two front feet and the other under the two rear feet of the machine, bolt them into the floor so that the space in between the 2 6 x 6's is 12-1/4". If you have a cement floor, we would suggest that you anchor these 6 x 6's into the floor with a threaded rod and a threaded expansion screw anchor. Place the 5033/DG on the 6 x 6's making certain that you have a #39 rubber foot under each leg. Secure the machine to the 6 x 6's with 4 each 3/8" x 4-1/2" lag screws.

2. The machine must be installed by a qualified electrician to a 115 volt 60 cycle power source.
3. The 5033/DG Paint Conditioner is designed to handle 2 cases of 4 - 1 gallon cans per case, a 5 gallon can or smaller containers ranging down to 1 gallon. If you are unable to reach the can or case with the upper jaw, place the odd size can adaptor supplied with the machine on the can or case and then secure with the upper jaw of the can clamp assembly. If you contemplate operating this machine with loads greater than specified above, we would suggest that you contact Red Devil, Inc. and give them full details of your operation.
4. Do not overtighten adjusting handle #71 which actuates the #70 upper plate container holder.
5. Before starting machine, make certain that you have tightened the clutch in order to hold the can clamp assembly (can holder) rigid to the #47 fork rod. If the container holder begins to slip or rotate while the machine is in operation, see II, Operating Instructions, paragraph 4.

6. Check oil level. This should be level with the mark etched on the oil level window located in the #45 hand hole cover. If oil level is under this mark, add enough good grade #20 weight oil until the proper level is reached.

## **II. OPERATING INSTRUCTIONS**

1. Place can in container holder, right side up and screw down #70 upper plate container holder by turning #71 cross handle with knobs until the #70 upper plate container holder lightly touches the container cover. Then, tighten the #71 cross handle with knobs three quarters (3/4) of a turn. Excessive tightening pressure may cause the #72 cross bar to fracture.
2. Rotate the container holder assembly to any desired position. Lock the clutch by turning the #59 handle for lock screw. Normally, the container holder assembly will be locked in the upright position. For "harder to mix" paints, lock the container holder assembly in the inverted or horizontal position. Excessive tightening pressure may cause the #57 clamp bar to fracture.
3. Turn timer knob to desired time setting. The machine will stop operating after desired time is reached.
4. **IMPORTANT** If the container holder assembly begins to rotate or slip while the machine is operating, STOP the machine by placing switch in "off" position. Repeat tightening procedure (locking of clutch) described in #2 of above. If #59 handle for lock screw touches the #47 fork rod before full tightening pressure is had, loosen #54 handle set screw, remove #59 handle for lock screw from hole in #55 lock set screw and set into other side of hole. Tighten #59 set screw. Keep the surfaces between #79 hub flange, #60 hub for container and rear bracket assembly free from any lubricant. If further adjustment of clutch is necessary, see section E.
5. To agitate a case of four (4) - 1 gallon cans, place the case on the #61 lower container holder. Place #84 odd can adapter on top of case and then secure with #70 upper container holder.

## **III. LUBRICATION AND MAINTENANCE**

1. Proper amount of oil has been placed in this machine at the factory. Since a certain amount may have escaped in shipment and handling, check the oil level window located in #45 hand hole cover. Oil should be maintained at a level with the black line on the oil gauge window. If additional oil is needed, add a SAE #20 weight oil, thru the small hole on top of the #32 housing. Oil change in this machine is not necessary.
2. Occasionally lubricate the side rods and #71 screw with any SAE oil.
3. After long periods of usage, it may be necessary to tighten the "V" belts. This is accomplished by turning the #14 hex head bolt on the back of the machine clockwise to tighten. Keep belts firm, however, not too tight.

#### **IV. SERVICING**

##### **A. #21A "V" BELT REPLACEMENT**

Remove #9 right belt guard and replace #21A V belts. The #21A belts are adjusted by turning the #14 hex head bolt in back of machine (outside). Turn clockwise to tighten.

##### **B. #72 CROSS BAR REPLACEMENT**

1. Remove the #71 handle & screw assembly by removing #67 flexlock nut and the #68 washer. Then, remove the #71 handle & screw assembly by rotating the unit counter clockwise. There is a spacer and 2 #74 washers as parts of this assembly. These must be removed before rotating the #71 handle & screw assembly thru the #72 crossbar.
2. The #73 roll pins hold the #72 crossbar to the side rods. Punch the #73 roll pins out.
3. Remove the broken #72 crossbar and replace with new one.
4. Replace the new #72 crossbar on the side rods, anchoring it in place with the 2 ea. #73 roll pins.
5. After the #71 handle & screw assembly has been inserted thru tapped hole in #72 crossbar, replace the #74 washers which are a part of this assembly. Place the assembly thru the hole in the #70 upper container holder and replace #69 spacer, #68 washer and #67 flexlock nut.

##### **C. #47 FORK ROD REPLACEMENT**

1. Remove #15 drain plug in lower rear portion of the machine and drain oil. Replace #15 drain plug.
2. Remove can clamp assembly (container holder) by removing #66 fork rod nut, #64 shake proof washer and #65 washer. Place block of wood behind #60 hub for container and tap the entire unit off the #47 fork rod. Remove #48 key.
3. Remove the #52 socket, #50 front bearing and #50 outer race by removing the #53 front bearing housing screws.
4. Remove #45 hand hole cover.
5. A "Universal Remover" is supplied with the purchase of each #47 fork rod or #36 crankshaft. Remove the #5 crankshaft adjusting screw (#37 Universal side), #41 washer and #40 oil throw. The #37 Universal assembly has two tapped holes in its side. Fasten the "Universal Remover" against the #37 Universal with 2 5/16 & 18 screws supplied with the unit. Place the large screws supplied with the "Universal Remover" through the threaded center hole of the remover and turn it (screw) clockwise. The outer #58 bearing and the #37 Universal (with #47 fork rod attached) will be pulled off the #36 crankshaft. Remove the "Universal Remover" from the #37 Universal. Pull the #47 Fork Rod out of the machine and remove the #37 Universal from the fork rod removing the 2 #42 lock nuts and 2 #43 Universal screws.

6. Replace the #37 universal onto the #47 fork rod with the 2 #43 universal screws. When replacing the screws, make certain that you screw them in evenly so the #37 universal is centered in the "fork". Spin the #37 universal assembly. Note the ease in which it spins. Then, tighten the 2 #43 universal screws evenly in very small increments, spinning the #37 universal after each tightening. Proper adjustment is had as soon as you encounter a slight drag when spinning the #37 Universal. Lock the #43 universal screws in place with 2 #42 lock nuts. Replace the #47 fork rod on the #36 crankshaft, making certain that tapped holes in the #37 universal are facing outside of the machine.
7. Place the #58 bearing on the #36 crankshaft. Drive the bearing onto the shaft with a block of wood and a hammer. Replace the #40 oil throw, #41 washer and #5 crankshaft adjusting screw. Tighten the #5 crankshaft adjusting screw until it appears that you have a snug fit. Grasp the upper and lower portions "fork" and rock it. If you feel any movement whatsoever, tighten the #5 crankshaft adjusting screw 1/2 turn and recheck for play between the bearings. Repeat this procedure until all play has been removed. Do not overtighten as this will cause binding.
8. Replace the #60 hub and can clamp assembly. Adjust the clutch as per IV Servicing, Section E, Can Clamp Assembly, paragraph 8.
9. Insert a 5 gallon container between the jaws and lock in place. Squirt some oil on the #58 bearings and #37 Universal assembly. Operate the machine for 5-10 seconds and check for knocking. If knocking occurs, tighten the #5 crankshaft adjusting screw 1/8 turn. Repeat procedure until knocking stops.
10. Replace the #46 cover gasket, #45 cover and fill machine with oil as per III Lubrication and Maintenance, Paragraph 1.

#### **D. #36 CRANKSHAFT REPLACEMENT**

1. Remove the can clamp assembly and the #47 fork rod as per IV Servicing, Section C, paragraphs 1 through and including 5; however, do not remove #43 universal screws and #42 lock nuts.
2. Remove the #9 belt guard right, 2 #21A "V" belts, #5 crankshaft adjusting screw, #4 washer, #2 crankshaft pulley, #3 woodruff key and #13 oil retainer.
3. Remove the #36 crankshaft assembly by pressing it out of position from right to left (to determine right or left, stand in front of machine, facing machine). The outside #16 bearing will come off. After the crankshaft has been taken out of the machine, remove remaining #58 and #16 bearings from the shaft. Since it is difficult to remove these bearings without damage to them, we recommend purchase of new #58 & #16 bearings. Make certain that both bearings have been pressed firmly against the stops on the new shaft, otherwise, you will run into considerable difficulties when attempting further adjustments.
4. Press the crankshaft into place, from left to right. Replace the outside #16 crankshaft bearing. We suggest that you order a new #13 oil retainer as there is that good possibility that the old one will be damaged when removed. Place some shellac on the outside metal surface of the #13 oil retainer and tap it into place. Insert the #3 woodruff key into position and replace the

#2 crankshaft pulley. Place the #4 washer on the #5 crankshaft adjusting screw and tighten the screw.

5. The next adjustment is important. While you are tightening the #5 crankshaft adjusting screw, slowly rotate the #2 crankshaft pulley. When the #2 crankshaft pulley begins to bind, loosen the #5 crankshaft adjusting screw a fraction of a turn (no more than 1/8 turn) and strike it with a hammer. Rotate the #2 crankshaft pulley and further check for binding. If no other binding, you have the proper adjustment. If still binding, repeat procedure. If this adjustment is too tight, binding will overheat and score the bearings and place an overload on the motor. If too loose, knocking will occur and result in premature wear of the bearings and possible crankshaft breakage.
6. Replace "V" belts referring to IV Servicing, Section A, #21A "V" belt replacement.
7. Replace the #47 fork rod and can clamp assembly referring to IV Servicing, C, #47 fork rod replacement, paragraph 6 through and including number 10. Replace the #9 belt guard right.
8. If knocking occurs at a later date, check the following. There is a slight possibility that you may not have had the bearings on either side of the crankshaft seated properly when you made your initial adjustment. These bearings may reset after the machine has been in operation for a period of time and leave you with too much clearance. Remove the #9 right belt guard. Rotate the #2 crankshaft adjusting screw 1/8 turn. Rotate the #2 crankshaft pulley and check for binding. If it feels the same as it felt prior to tightening the #5 crankshaft adjusting screw, tighten another 1/8 turn. Rotate the #2 crankshaft pulley and check for binding. If it feels the same as it felt prior to tightening the #5 crankshaft adjusting screw, tighten another 1/8 turn and again rotate the pulley and check the "feel". Repeat procedure until you feel it turn and strike it (screw) with a hammer. Operate the machine to see if knocking has stopped. If not, further adjustments may be necessary on the other side of the crankshaft(#37 universal side). Remove #15 housing (drain) plug and drain the oil. Replace the plug. Remove the #45 hand hole cover and repeat adjusting procedures outlined in IV Servicing, Section C, #47 Fork Rod Replacement, paragraph #7. After proper adjustment is had, replace the #45 hand hole cover and add oil as indicated in III, Lubrication and Maintenance, paragraph 1. Approximately two quarts of oil will give you the desired level. For the exact level, check the line etched on the oil level window which is located in the #45 hand hole cover.

#### **E. CAN CLAMP ASS'Y (Container in Holder)**

1. Install #60 hub on shaft #47, making sure key #48 is in place.
2. Install washers #64 #65 respectively and tighten #60 hub securely to #47 shaft with nut #66. Install clamp bar #57 to hub #60 with 5/8" bolts, #56. Install #55 clamp screw into center threaded hole of #57 clamp bar must not protrude thru other side of #57.
3. install the complete container holder assy and hub flange #79 to hub #60 with one #56 bolt. Rotate the can clamp assembly slowly and tighten #56 bolt until assembly starts to bind, then loosen bolt just enough to allow the clamp assembly to rotate with a very slight drag. Repeat this procedure



with the other #56 bolt. Lock the two bolts with the two jam nuts, #78. When properly adjusted, there should be a slight drag when rotating the' clamp assembly.

4. Turn the #55 clamp screw in so that it touches the hub #60, insert handle rod #59 and tighten set screw, #54.
5. Secure the container of paint in the can clamp assembly and then rotate it (can clamp assembly) to any desired position. Lock the clutch by tightening the #55 clamp screw with the #59 handle.

#### SPECIFICATIONS FOR

#### MODEL 5033/DG PAINT CONDITIONER

TAKES: 1 to 5 gallon cans U.S. Standard as well as Imperial Standard. Also 1 carton of four 1 gallon cans.

BASE MEASUREMENTS: 11-3/4" wide, 19-3/4" long, 30" high. Operating space 39" x 15-1/2".

MOTOR EQUIPMENT: 1/2 H.P., 60 cycles, 115 volts, A.C., explosion-proof.

OSCILLATION: Triple three-way action.

LUBRICATION: Operates in a bath of oil that requires only occasional addition of good grade 20W SAE oil. Built-in, glass window oil level gauge.

MOUNTING: Recommended to be secured to floor or strong portable base. Holes are bored in each of four corners of the base.

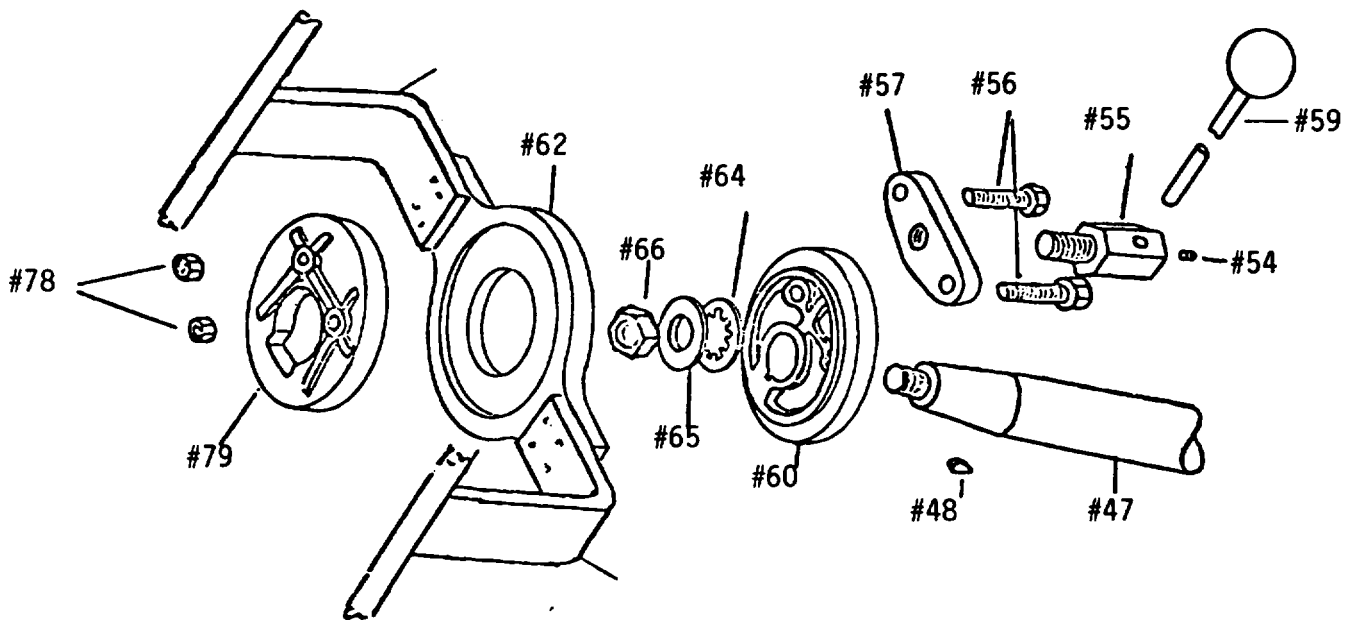
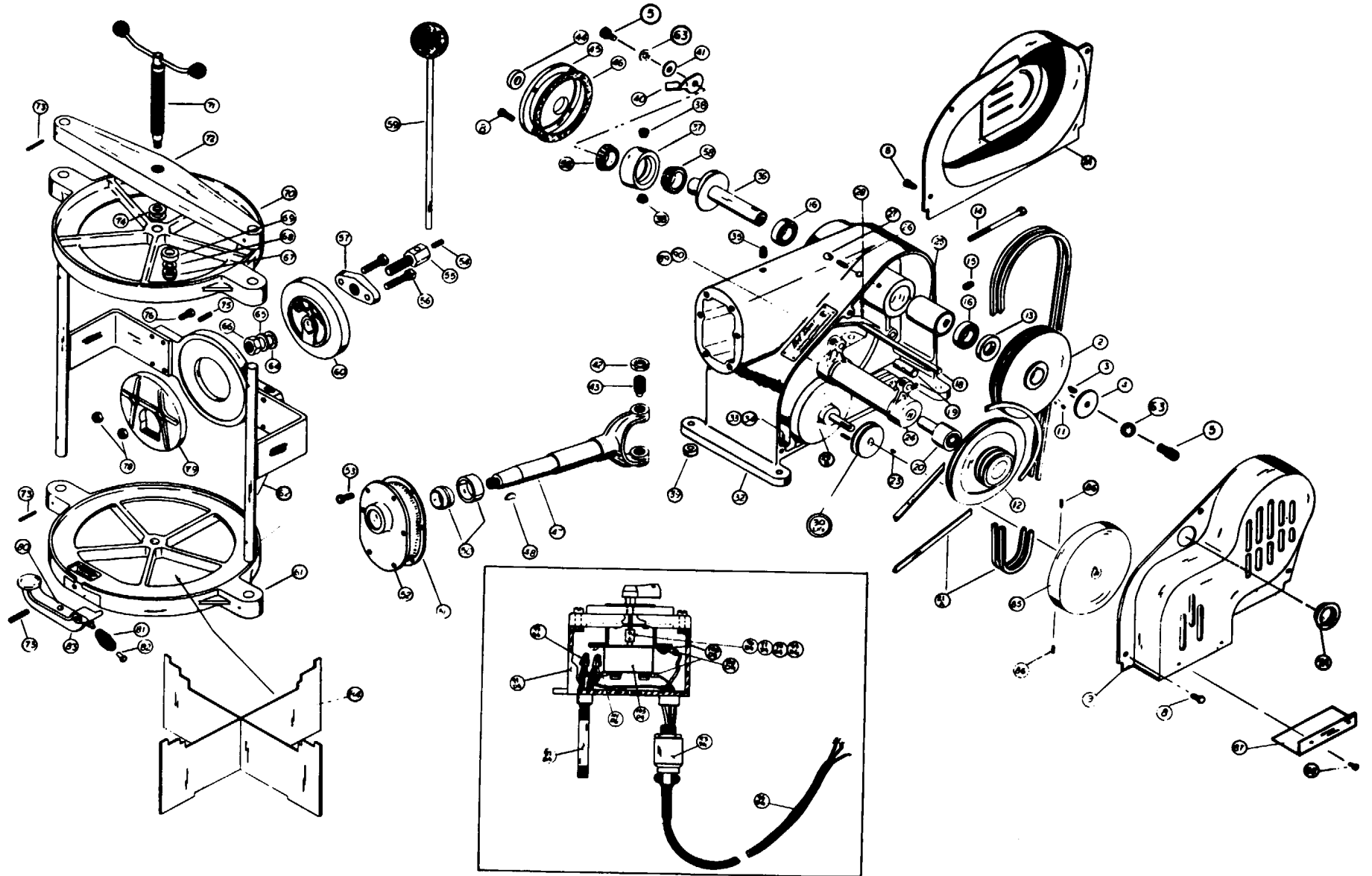

DIAGRAM OF PARTS FOR NO. 5033  
5-GALLON PAINT MIXER



**PARTS LIST**  
**FOR**  
**5 GALLON GOV'T PAINT CONDITIONER**  
**5033-DG**

<b><u>ITEM NO.</u></b>	<b><u>PART NO.</u></b>	<b><u>DESCRIPTION</u></b>	<b><u>QUANTITY</u></b>
1A	9-4358	Cover, Explosion Proof	1
2	9-3555	Pulley, Crankshaft	1
3	9-1335	Key, #15 Woodruff	1
4	9-1256	Washer 17/32 x 1/2	1
5	9-3147	Screw, Socket Head 1/4 - 20 x 1"	2
7A	9-5982	Timer Hole Plug	1
8	9-3148	Screw, 5/16 - 18 x 3/4	10
9	9-5968	Belt Guard	1
12	9-4286	Pulley	1
13	9-3607	Oil Seal, Type 480	1
14	9-1313	Bolt, Hex 3/8 - 16 x 5	1
15	9-1691	Plug, 1/4" Pipe	1
16	6-9162	Bearing, Cup & Cone Assy (Ass'y of 9-3294 & 9-3295)	2
18	9-4419	Pin, Hinge	1
19	9-1295	Block, Pivot	1
20	9-4285	Bearing	1
21A	9-5962	Belt, Vee Static Disipating (60 Hz Only)	3
23	9-1334	Key, Woodruff	1
24	9-4284	Housing, Counter Shaft	1
25	9-3079	Spacer	1
26	9-1261	Screw, Set 3/8 - 16 x 3/4"	1
27	9-2643	Plug, Snap Hole	1
28	9-4414	Pin, Cotter 3/32 x 1 1/2	2
29B	5-3825	Motor, Explosion Proof (1/2 HP, 115-230 VAC, 1PH, 60 Hz)	1
30DG	9-3814	Pulley, Motor (5033-DG Only)	1
32	9-1303	Housing, Main	4
33	9-1592	Screw, Hex 1/4 - 20 x 3/4	4
34	9-1688	Washer, 1/4 ID x 1" OD	4
35	9-2140	Plug, 1/4" Poly Pipe	1
36	9-3698	Crankshaft	1
37	6-9178	Universal Bearing Housing	1

<u>ITEM NO.</u>	<u>PART NO.</u>	<u>DESCRIPTION</u>	<u>QUANTITY</u>
38	9-3722	Bearing Cone	2
39	9-3275	Feet, Rubber	8
40	9-3705	Guard, Oil Splash	1
41	9-3706	Washer 17/32 x 1 3/4	1
42	9-1292	Nut, Hex	2
43	9-3700	Bearing Screw	2
44	9-1344	Oil Window	1
45	9-1309	Hand Hole Cover	1
46	9-1310	Gasket, Hand Hole Cover	1
47	9-1671	Fork Rod	1
48	9-1331	Key #24 Woodruff	1
50	9-6193	Spherical Bearing (Replaces 9-3072 & 9-3169)	1
51	9-1314	Gasket, Front Bearing	1
52	9-3067	Bearing Housing	1
53	9-1690	Screw, Socket Head 7/16 - 14 x 1	6
54	9-1685	Screw, Set 1/4 - 20 x 1/4	1
55	9-4000	Screw, Hub Clamp	1
56	9-4011	Screw, Hex Cap 5/8 - 18 x 14	2
57	9-3999	Bar, Clamp	1
58	9-3294	Cone, Bearing	2
59	6-9711	Handle	1
60	9-3997	Hub	1
61	9-4030	Lower Container Holder	1
62	6-9709	Rear Bracket & Guide Rod Assem. (Domestic)	1
63	9-6235	Washer, 1/2" Internal Tooth Lock	2
64	9-1662	Washer, 7/8 Lock	1
65	9-1661	Washer, 7/8" ID	1
66	9-1337	Nut, Jam 7/8 - 14	1
67	9-1682	Nut, Lock 1/2 - 13	1
68	9-1660	Washer, 5/8 ID SAE	2
69	9-2766	Sleeve	1
70	9-4029	Upper Container Holder	1
71	6-9027	Handle & Screw Ass'y.	1
72	9-4028	Cross Bar	1

<u>ITEM NO.</u>	<u>PART NO.</u>	<u>DESCRIPTION</u>	<u>QUANTITY</u>
73	9-3208	Roll Pin 5/16 x 1 1/2	5
74	9-2747	Washer Thrust	2
75	9-3203	Roll Pin 5/16 x 1 1/4	4
76	9-3992	Bolt 7/16 - 14 x 1 1/4	4
78	9-4071	Nut, Light Jam 5/8 - 18	1
79	9-3998	Flange, Hub	2
80	9-2756	Bumber, Rubber	1
81	9-1341	Spring, Lifting Lever	1
82	9-3209	Rivet, 5/16 x 3/4	1
83	9-1324	Lever, Lifting Lever	1
84	6-9472	Odd Can Adapter	1
85	9-5297	Fly Wheel	1
86	9-5969	Screws, Self Locking Set	2
87	9-5970	Hand Guard	1
88	9-2046	Screws, Self Tapping	2
(NA) 89	9-3196	Specification Plate	1
(NA) 90	9-2254	Screws, Drive Type "U"	4
91DG	5-3819	Enclosure - Includes Housing, Cover Bracket, Screws, Bushing & Selector Switch Handle	1
92DG	5-4042	Galvanized Nipple 1/2" x 6"	1
93DG	5-3817	Cord Connector	1
94DG	5-3816	10' Cord	1
95DG	5-3750	Wire Nut	2
96DG	9-3865	Universal	1
97DG	9-3866	Universal Shaft	1
98DG	9-6196	Roll Pin	1
99DG	9-6195	Set Screws	2
100DG	5-3876	Ring Terminal	2
101DG	5-1253	Ring Terminal	1
102DG	9-5731	#8 External Tooth Lockwasher	1
103DG	5-3815	Timer, Dial Plate, and Terminal Screws	1

Footnotes: (NA) - Not available as replacement part

**VI. Instructions for using "odd size can and carton adapter".**

1. The "odd size can and carton adapter" consists of 2 pieces, both are slotted. Insert the slot of one into the slot of the other piece so that they form a cross.
2. To use with a gallon can, place the can on the lower container holder (#61). Place the adapter on the can (cutout portion facing downward). Screw down #70 upper plate container holder by turning #71 handle and screw assembly. Lock clutch by tightening #59 handle for lock screw.
3. To use with a carton of 4 1 gallon cans, place the carton on the lower container holder (#61). Place the adapter on the carton (flat portion facing carton, cutout portion facing upward). Screw down #70 upper plate container holder by turning #71 handle and screw assembly. Lock clutch by tightening #59 handle for lock screw.

**VII. Instructions for requisitioning parts not identified by FSN**

When requisitioning parts not identified by Federal Stock Number, it is mandatory that the following information be furnished the supply officer:

1. Manufacturer's Federal Supply code number: 89093.
2. Manufacturer's part number exactly as listed herein.
3. Nomenclature exactly as listed herein, including dimensions if necessary.
4. Manufacturer's model number: 5033/DG
5. Manufacturer's serial number (end item).
6. Any other information such as type, frame number, and electrical characteristics, if applicable.
7. If DD Form 1348 is used, fill in all blocks except 4, 5, 6 and Remarks field in accordance with AR 725-50.

Complete form as follows:

- a. In blocks 4, 5, and 6, list manufacturer's Federal Supply code number: (89093) followed by a colon and manufacturer's part number for the repair part.
- b. Complete remarks field as follows:  
Noun: (nomenclature of repair part)  
For: NSN 4940-00-251-6475  
Mfr:  
Model: 5033/DG  
Serial: (of end item)  
Any other pertinent information such as frame number, type, dimensions, etc.
- c. All parts may be ordered from any of the authorized service centers on the enclosed service center list.

By Order of the Secretary of the Army:

Official:

E. C. MEYER  
*General, United States Army*  
*Chief of Staff*

J. C. PENNINGTON  
*Major General, United States Army*  
*The Adjutant General*

Distribution:

To be distributed in accordance with Special List.

\*U.S. GOVERNMENT PRINTING OFFICE: 1993 - 342-421/80743

RECOMMENDED CHANGES TO EQUIPMENT TECHNICAL PUBLICATIONS



THEN... JOT DOWN THE DOPE ABOUT IT ON THIS FORM, CAREFULLY TEAR IT OUT, FOLD IT AND DROP IT IN THE MAIL!

**SOMETHING WRONG WITH THIS PUBLICATION?**

FROM: (PRINT YOUR UNIT'S COMPLETE ADDRESS)

DATE SENT

PUBLICATION NUMBER      PUBLICATION DATE      PUBLICATION TITLE

BE EXACT... PIN-POINT WHERE IT IS				IN THIS SPACE TELL WHAT IS WRONG AND WHAT SHOULD BE DONE ABOUT IT:
PAGE NO.	PARA-GRAPH	FIGURE NO.	TABLE NO.	

TEAR ALONG PERFORATED LINE

PRINTED NAME, GRADE OR TITLE, AND TELEPHONE NUMBER

SIGN HERE:

DA FORM 2028-2 JUL 79

PREVIOUS EDITIONS ARE OBSOLETE.

P.S.—IF YOUR OUTFIT WANTS TO KNOW ABOUT YOUR RECOMMENDATION MAKE A CARBON COPY OF THIS AND GIVE IT TO YOUR HEADQUARTERS.



**TM 9-4940-542-14&P AGITATOR, PAINT SHAKER - JUNE 1981**

**PIN: 049115-000**